

Maxxam Cat 6A Shielded Keystone Jack

6A

 3rd PARTY TESTING

**4pr
Tool
Compatible**
**110
Tool
Compatible**
**KRONE
Tool
Compatible**

- ➔ **Independently verified performance**
- ➔ **Component compliant**
- ➔ **Easy termination**
- ➔ **Low profile**
- ➔ **Use in patch panels and outlets**

Features:

- ➔ Die cast metal body
- ➔ Low Profile – 38mm overall depth
- ➔ 360° screen connection
- ➔ Multiple termination options
 - Krone, 110, 4pr or Toolless
- ➔ Compatible with all Keystone mounting options
- ➔ 3rd Party verified standards compliance
- ➔ 3rd Party ISO11081 2nd Edition verification

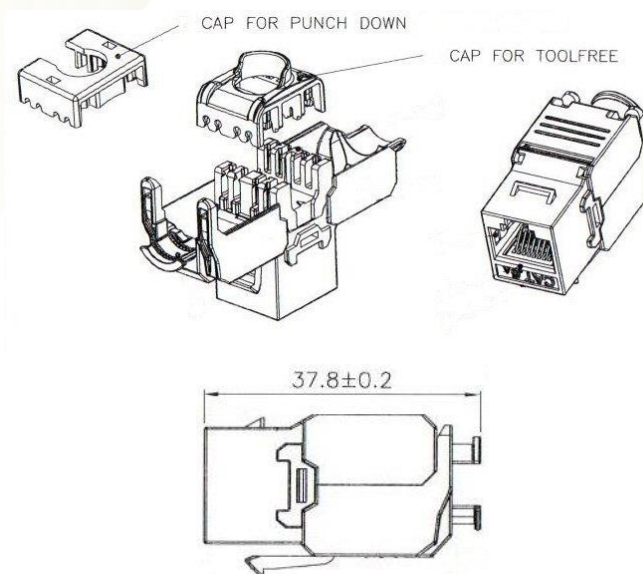

Product Overview:

The Maxxam Cat 6A Shielded Keystone Jack offers independently verified Cat 6A component compliant performance and supports high speed protocols such as 10G Ethernet. The Jack is backwards compatible to all preceding cabling categories, ensuring support of all IP applications.

The Jack is compatible with a wide range of patch panels and work area fascias, including flat and angled options, and the low profile design enables enhanced cable management in back boxes.

The Jack body is constructed using robust die-cast Zinc offering excellent durability and superior shielding performance.

There are multiple termination options, including Punch down with either Krone or 110 tools, 4pr termination using the Maxxam Termination Tool or toolless using the special termination cap and clamshell can design.

Technical Data:

Standards Compliant	ANSI/TIA-568-C.2, ISO/IEC 11801, BS EN 50173
Dimensions	38mm x 16mm x 20mm
Housing	Nickel Plated Die-cast Zinc
RJ45 Contacts	Phosphor Bronze with 50 μ Gold over 100 μ Nickel Plating
IDC Contacts	Phosphor Bronze with Tin Plating
IDC Wire Gauge	22-26 AWG
RJ45 Life	Minimum 750 mating cycles
Operating Temperature Range	-10 to +60°C
Dielectric Strength	1,000V RMS at 60Hz for 1 minute
Insulation Resistance	500m Ω minimum
Contact Resistance	2m Ω per contact
Relative humidity (Operational)	93% Maximum Non-condensing

Supported Applications:

- ➔ 10Base-T Ethernet
- ➔ 100BASE-TX Fast Ethernet
- ➔ 1000BASE-T Gigabit Ethernet
- ➔ 10GBASE-T 10 Gigabit Ethernet
- ➔ Digital and Analogue Voice
- ➔ ISDN

Ordering Information:

Part No.	Description
XX6A0010	Maxxam Cat 6A Shielded Keystone Jack

Warranty:

The Maxxam 25 year Warranty guarantees Permanent Link and Channel performance to the relevant cabling standard when Maxxam cabling products are installed by a Maxxam Installer Partner. Performance to the relevant cabling standards ensures support of all applications designed to run over the cabling system.

Maxxam
25YR
Warranty

Maxxam offers a comprehensive range of high performance copper and fibre optic cabling solutions backed up with industry leading service and support.

max
xam